

DESIGN AND CONSTRUCTION OF A ROTARY DEVICE FOR THE STUDY OF CORROSION IN INDUSTRIAL STEELS

Ilse Zurisaday Ramírez León¹, Héctor Herrera Hernández², Carlos Omar González Morán¹

UNIVERSIDAD AUTÓNOMA DEL ESTADO DE MÉXICO, CU UAEM Valle de México

¹Laboratorio de Investigación en Materiales y Procesos Inteligentes,

²Lab. de Inv. en Electroquímica y Corrosión de Mat. Ind

¹iramirezl003@alumno.uaemex.mx, ²hherrerah@uaemex.mx, ¹cogonzalezm@uaemex.mx

Abstract: This work presents the design and construction of a rotary system for the dynamic study of corrosion in industrial steels. The prototype is conceived as a low-cost alternative to commercial equipment such as the Rotating Disk Electrode (RDE), whose cost and operational limitations restrict its use in laboratories and educational institutions.

The developed system employs a direct current (DC) electric motor coupled with propellers manufactured by 3D printing using PLA material, capable of generating dynamic flow in aqueous NaCl solutions. The electronic control, based on an Arduino board, allows regulation of both rotation speed and direction (counterclockwise, clockwise, and alternating modes), providing experimental flexibility. The tests enable the generation of graphs where clear differences compared to static analyses can be observed.

This prototype represents an innovation in the field of materials engineering, as it reproduces dynamic flow conditions that simulate industrial environments, with potential applications in research, teaching, and technological development focused on analyzing metal resistance in corrosive environments.

Keywords: Electrochemical cell, CAD design, 3D printing, Arduino, Dynamic state.

I. INTRODUCTION

Corrosion in industrial steels represents one of the most relevant and costly problems for modern engineering, as it directly affects the durability, safety, and performance of metallic structures and components. This phenomenon is evident in strategic sectors such as construction, mining, fluid transportation, the naval industry, and heavy machinery, where steels are exposed to aggressive environments that accelerate their deterioration. The

economic losses derived from the repair, replacement, and mitigation of damage associated with corrosive processes are estimated to reach billions of dollars worldwide, which has driven the search for more precise and representative methods for its study [1–4].

Traditionally, electrochemical corrosion analyses are carried out under static conditions, where the electrolyte remains at rest and species diffusion occurs mainly through concentration gradients. Although these systems allow the characterization of fundamental parameters such as corrosion potential, current density, and polarization resistance [5], they present significant limitations when attempting to reproduce real service conditions. The absence of controlled flow (static conditions) prevents the analysis of the mechanical drag of corrosive species, the continuous renewal of dissolved oxygen, and the removal of unstable passive layers.

One of the most widely used tools to simulate dynamic conditions in the laboratory is the Rotating Disk Electrode (RDE) [6]. This device allows control of the angular velocity of the working electrode and generates a well-defined hydrodynamic regime, facilitating mass transport analysis under laminar conditions. However, commercial RDE systems present restrictions associated with sample size, equipment cost, and the inability to adapt more complex experimental geometries. Furthermore, the flow pattern generated by an RDE does not always reproduce the turbulence and mixed regimes present in real industrial systems.

In response to this problem, there is a need to develop versatile, low-cost experimental alternatives adaptable to different configurations that allow corrosion to be studied under controlled flow without relying exclusively on high-cost commercial equipment. In this context, the integration of additive manufacturing technologies, such as 3D printing, together with programmable electronic systems based on

microcontrollers, opens new possibilities for the design of customized electrochemical devices [7].

The present work focuses on the design, fabrication, and implementation of a dynamic electrochemical cell developed through 3D printing and integrated with an Arduino-based electronic control system. The prototype makes it possible to induce controlled electrolyte movement at different rotational speeds and in different directions (counterclockwise, clockwise, and alternating), generating hydrodynamic conditions comparable to real industrial scenarios where flow plays a determining role in material degradation.

The central hypothesis establishes that increasing the flow velocity induced by the rotary system will increase corrosion kinetics due to enhanced mass transfer, intensified transport of corrosive species, and destabilization of protective films. The development of the prototype not only seeks to validate this hypothesis but also to provide an innovative experimental tool for materials science and technology, with potential applications in academic research, industrial laboratories, and service-life prediction studies.

II. METHODOLOGY

2.1 Research Approach

The present research was conducted under an applied, experimental, and quantitative approach aimed at the technological development of a functional prototype for flow-assisted corrosion studies. The applied nature of the study lies in its practical objective: to design a device capable of reproducing dynamic conditions representative of real industrial environments. Unlike purely theoretical research, this work integrates mechanical design, additive manufacturing, control electronics, and electrochemical analysis into a complete experimental system.

The experimental approach allowed controlled manipulation of independent variables such as rotational speed and direction of rotation, evaluating their effect on dependent variables including corrosion current density, corrosion potential, and polarization resistance. The quantitative methodology was based on the acquisition of electrochemical data using a potentiostat/galvanostat, ensuring statistical analysis of the results.

The methodological design included two main stages:

- (1) Development and validation of the mechanical-electronic prototype
- (2) Calibration of the rotation system and verification of RPM using a frequency meter.

2.2 Design and Fabrication of the Prototype

The prototype development began with three-dimensional modeling of each component using 3D modeling software (Tinkercad), as shown in Figure 1, allowing geometry optimization prior to physical fabrication. Structural supports, electrode adapters, a motor coupling system, and interchangeable propellers (Figure 2) capable of generating different flow patterns (vortex) were designed.

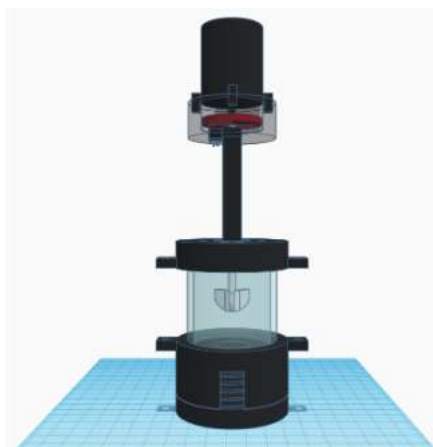

Figure 1: CAD design of the electrochemical cell



Figure 2: CAD design of the propellers

Fabrication was carried out using 3D printing with 1.75 mm PLA (polylactic acid) filament, a layer resolution of 0.2 mm, an extrusion temperature of 210 °C, and a heated bed set at 60 °C, as shown in Figure 3. These parameters allowed the production of components with adequate mechanical strength and dimensional stability. Additive manufacturing provided significant advantages, including cost reduction, ease of part replacement, and the possibility of modifying designs without requiring complex industrial processes.

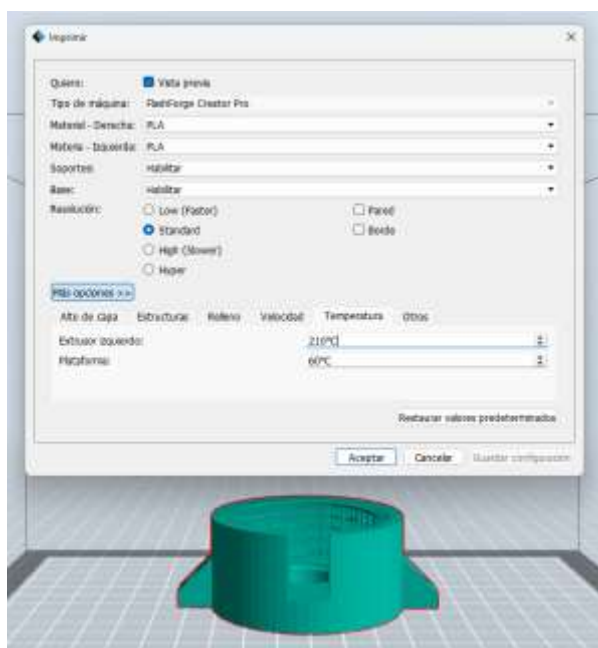

Figure 3: Printing configuration

The rotary system was integrated into a conventional three-electrode electrochemical cell consisting of a working electrode (WE), a reference electrode (RE), and a counter electrode (CE), as shown in Figure 4. The design ensures that the metallic sample remains fixed while the electrolyte is stirred by the propeller, thereby generating a controlled flow.

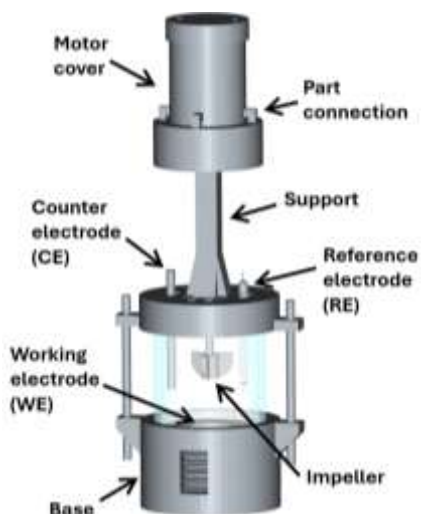

Figure 4: Electrochemical cell

Different propeller designs will be evaluated to analyze vortex formation and the distribution of shear stresses on the metallic surface, allowing correlation between impeller geometry and the electrochemical response.

2.3 Electronic Control System

The control system was based on an Arduino UNO board

equipped with an ATMEL ATMEGA328P microcontroller, integrated with an L293D H-bridge to regulate the direction and speed of the direct current (DC) motor. The circuit was first simulated in Tinkercad (Figure 5) and subsequently assembled on a breadboard (Figure 6). Three programmable operating modes were implemented: counterclockwise rotation, clockwise rotation, and alternating rotation every 3 seconds.

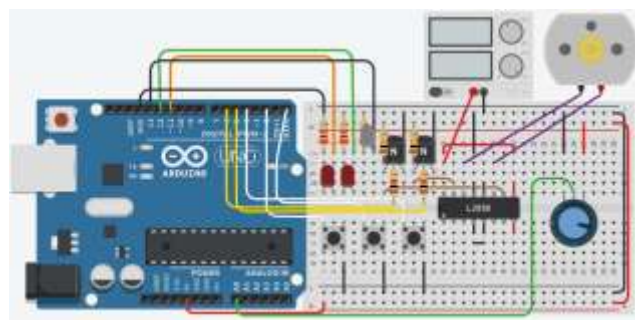

Figure 5: System simulation

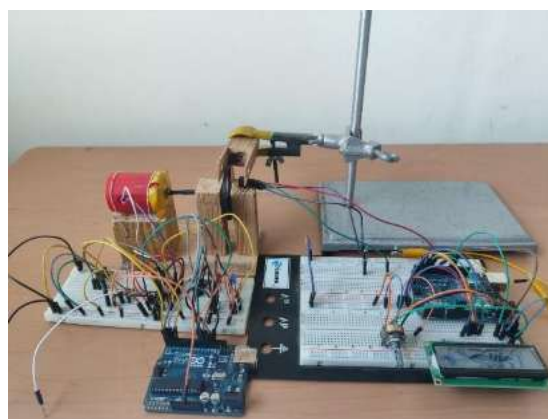

Figure 6: System on protoboard

The rotational speed was regulated using pulse width modulation (PWM), enabling precise adjustments and stability in the RPM. Indicator LEDs were incorporated to display the active operating mode and ensure immediate visual monitoring during the experiments.

The electronic system provides experimental repeatability, as it allows constant speeds to be maintained over extended periods, which is an essential condition for reliable electrochemical studies.

2.4 Electrochemical Characterization

Electrochemical characterization was performed in a NaCl solution using VersaSTAT 4 and PARSTAT 4000 potentiostat/galvanostat systems, as shown in Figure 7. To evaluate its performance, the following techniques will be applied:

- Linear polarization (Tafel)

- Polarization resistance (R_p)
- Electrochemical impedance spectroscopy (EIS)
- Electrochemical noise.

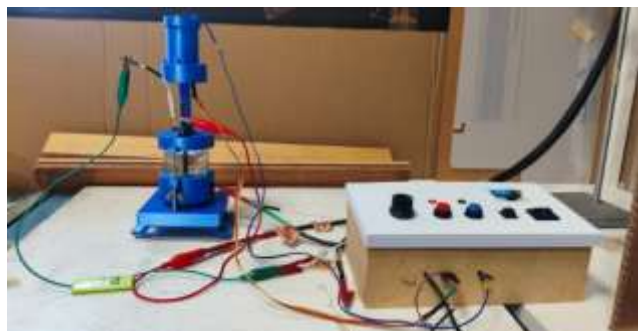

Figure 7: System assembly for testing

III. RESULTS

The generation of the vortex in the evaluated stirring system is a direct consequence of the transfer of momentum from the propeller to the fluid contained within the electrochemical cell. Upon operation, each blade of the propeller mechanically interacts with the electrolyte, inducing fluid motion.

The hydrodynamic behavior observed in Figure 8, corresponding to rotational speeds of 0, 80, 120, and 300 RPM, demonstrates the progressive evolution of the flow regime as the rotational speed increases.



Figure 8: Different speeds to analyze the vortices

The depth and stability of the observed vortex depend directly on operating parameters such as agitation speed (N), propeller diameter (D), and the rheological properties of the fluid, particularly its dynamic viscosity (μ). At higher rotational speeds, the Reynolds number of the system increases, promoting the transition toward a turbulent regime that enhances the mass transfer coefficient.

From an electrochemical perspective, the intensification of convective flow induced by the vortex contributes to a reduction in the thickness of the hydrodynamic boundary layer at the electrode surface. This condition facilitates the transport of reactive species toward the electrode–electrolyte interface, optimizing oxidation–reduction processes and improving the overall efficiency of the system.

Consequently, the agitation mechanism not only determines the formation and morphology of the central

vortex but also constitutes a critical factor in mixing efficiency, dynamic system stability, and optimization of chemical species transport within the developed electrochemical cell.

To date, the experimental system has been evaluated through a single electrochemical test using the developed cell, operating at a constant agitation speed of 80 RPM (Figure 9). Electrochemical characterization at 80 RPM allowed evaluation of the influence of different concentrations of the inhibitor C_9H_8O (0, 2, 4, 8, 12, 16, and 18 mL) on the kinetics of the corrosion process. The results demonstrate an inversely proportional relationship between inhibitor concentration and the electrochemical activity of the system.

In the absence of inhibitor (0 mL), the highest current densities were recorded in both anodic and cathodic regions, indicating an active corrosion process enhanced by agitation-induced convective transport. As the inhibitor concentration increased, a progressive decrease in current density was observed, suggesting a reduction in the corrosion rate.

The inhibitor molecules interact with active sites on the metal surface, forming a protective film that increases charge transfer resistance and limits the exchange of electroactive species at the electrode–electrolyte interface.

At the highest concentrations (16 and 18 mL), the system exhibited the lowest electrochemical activity, indicating more efficient and stable inhibitor coverage. Under the 80 RPM condition, agitation promotes homogeneous distribution of the compound without compromising the stability of the adsorbed protective film.

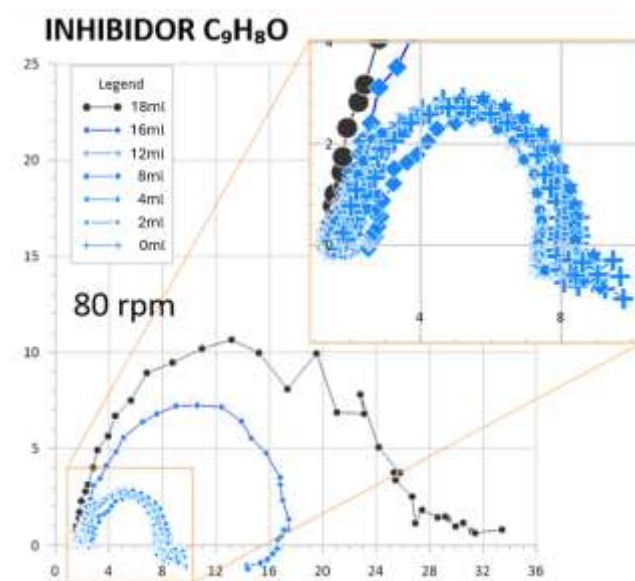

Figure 9: Comparison chart

IV. DISCUSSION

From a technological perspective, the integration of 3D

printing and Arduino UNO-based electronics demonstrates that high-functionality scientific instrumentation can be developed at low cost. Additive manufacturing enabled the design of customized geometries, easy replacement of components, and modification of experimental configurations without the need for complex industrial processes. This approach democratizes access to advanced electrochemical research tools, particularly in academic laboratories with limited resources.

In the industrial context, the results provide experimental evidence regarding the vulnerability of structural steels under high-flow regimes. The generated data can be used to improve predictive service-life models, optimize protective coatings, and design corrosion mitigation strategies in fluid transport systems.

V. CONCLUSIONS

The research conducted enabled the design, fabrication, and experimental validation of a dynamic electrochemical cell based on additive manufacturing and programmable electronic integration. The prototype demonstrated the capability to generate controlled hydrodynamic regimes, directly influencing the corrosion kinetics of industrial steels.

The interdisciplinary approach adopted, combining mechanical engineering, electronics, and electrochemistry, resulted in the development of an experimental tool with potential applications in academic research, industrial material evaluation, and flow-assisted corrosion studies.

Finally, the prototype opens new opportunities for investigating complex phenomena such as erosion-corrosion, transient flow effects, and predictive degradation modeling, establishing itself as a significant contribution to the field of materials science and technology.

REFERENCES

- [1] Marcus P, Oudar J. Corrosion Mechanism in Theory and Practice. 1st ed. New York: Marcel Dekker, Inc.; 1995. 641p. DOI: 10.1201/9780203909188.
- [2] American Society for Metals. ASM Handbook, Vol. 13A Corrosion: Fundamentals, Testing and Protection. 10th ed. Ohio: ASM International; 2003. 2597p. DOI: 10.31399/asm.hb.v13b.9781627081832.
- [3] Morcillo M, De la Fuente D, Díaz I, Cano H. Atmospheric corrosion of mild steel. *Revista de Metalurgia*. 2011;47(5): 1-19. DOI: 10.3989/revmetalm.1125.
- [4] Corrosion LD. Surface Chemistry of Metals. 1st ed. Vol. 614p. Florida: Taylor and Francis Group; 2007. DOI: 10.1201/9781439807880.
- [5] Kelly RG, Scully JR, Shoesmith DW, Buchheit RG. *Electrochemical Techniques in Corrosion Science and Engineering*. 1st ed. New York: Marcel Dekker Incorporation; 2002. 440p. DOI: 10.1201/9780203909133.
- [6] Liang W. Surface modification of AISI 304 austenitic stainless steel by plasma nitriding. *Applied Surface Science*. 2003;211:308-314. DOI: 10.1016/S0169-4332(03)00260-5
- [7] Liu RL, Yan MF. Improvement of wear and corrosion resistances of 17-4PH stainless steel by plasma nitrocarburizing. *Materials and Design*. 2010;31:2355-2359. DOI: 10.1016/j.matdes.2009.11.069